

Product Information:

- Architectural Batten Profile for sunshades, grilles, privacy screens, signage, decorative elements, screen wall & fencing.
- Mechanically attach with internal fastening
- Finishes: Solid colors, woodgrains and specialty finishes available
- Matched finish on press fit End Caps available
- Extruded aluminum shape
- Paint finish testing: AAMA 2604
- Class "A" Fire Rating
- Standard profile length is 24'-0"
- Lengths less than 24'-0" available upon request
- See Batten Extrusion Line Card for other Components

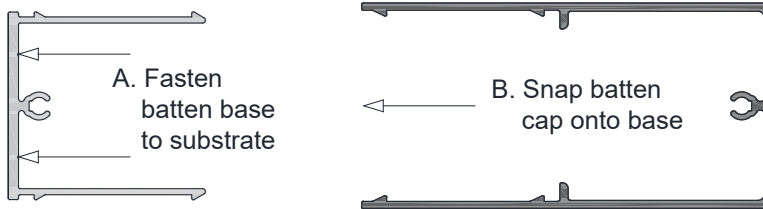

Options: Back side of A can be left unfinished if not exposed

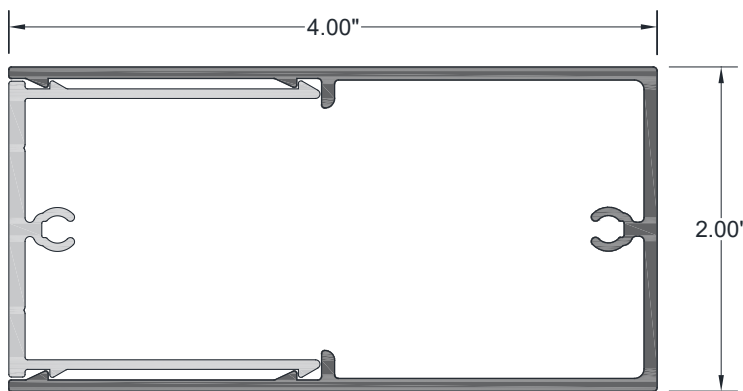

2" X 4" Vertical Interlocking Batten

*typical 0.080" wall thickness