

## Mosaic Alumaboard 4" x 2" Batten Assembly

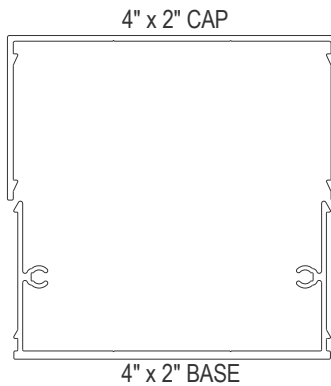

\*Options: Back side of 'BASE' can be left unfinished if not exposed

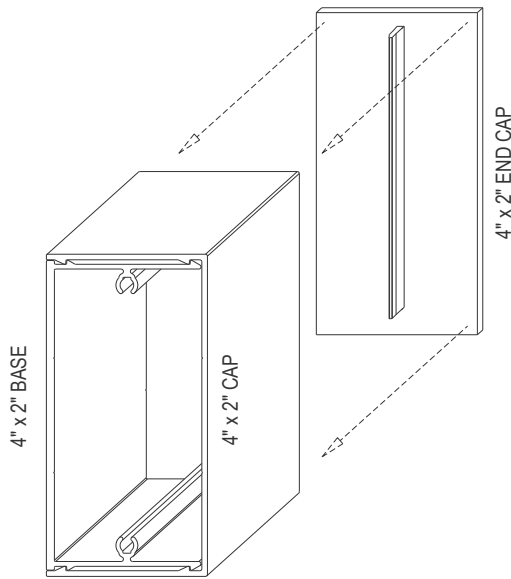
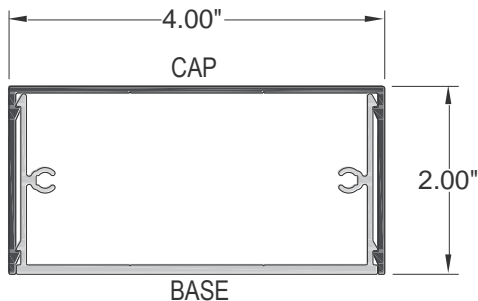

4" x 2" Batten

### Product Information:

- Architectural Batten Profile for sunshades, pergolas, privacy screens, signage, decorative elements, soffits and siding, screen wall & fencing.
- Mechanically attach with internal fastening.
- Numerous attachment methods based on application.
- Finishes: Solid colors, woodgrains and specialty finishes available
- Matching finish on press fit End Cap is available
- Extruded aluminum shape
- Paint finish testing: AAMA 2604
- Class "A" Fire Rating
- Standard profile length is 24'-0"
- Lengths less than 24'-0" available upon request
- See Batten Extrusion Line Card for other Components