

## Mosaic Alumaboard Batten 2" X 10" Assembly

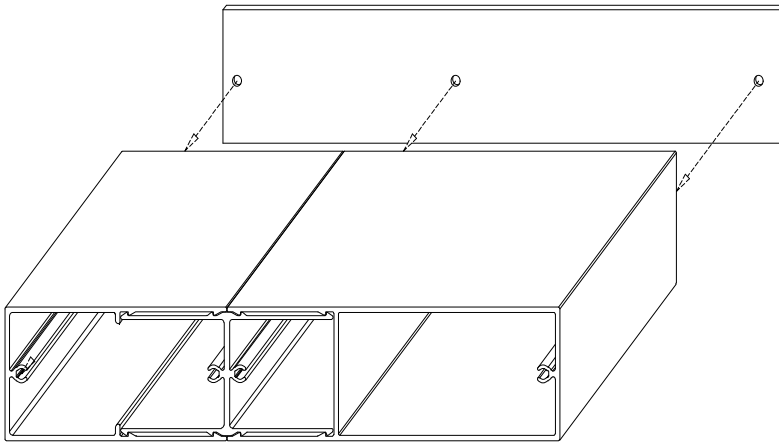

### Product Information:

- Architectural Batten Profile for sunshades, grilles, privacy screens, signage, decorative elements, screen wall & fencing.
- Mechanically attach with internal fastening.
- Finishes: Solid colors, woodgrains and specialty finishes available.
- Matched finish on End Caps available.
- Extruded aluminum shape.
- Paint finish testing: AAMA 2604.
- Class "A" Fire Rating.
- Standard profile length is 24'-0".
- Lengths less than 24'-0" available upon request.
- See Batten Extrusion Line Card for other Components.

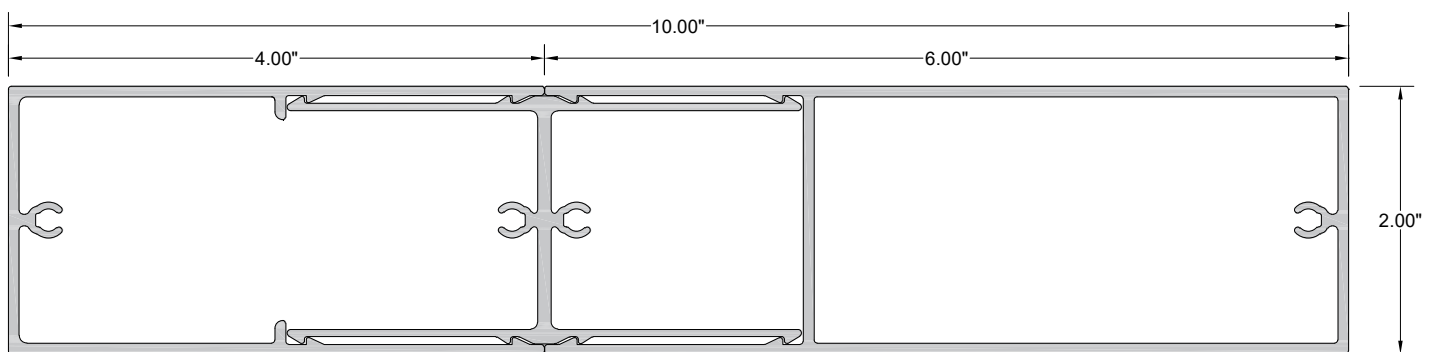
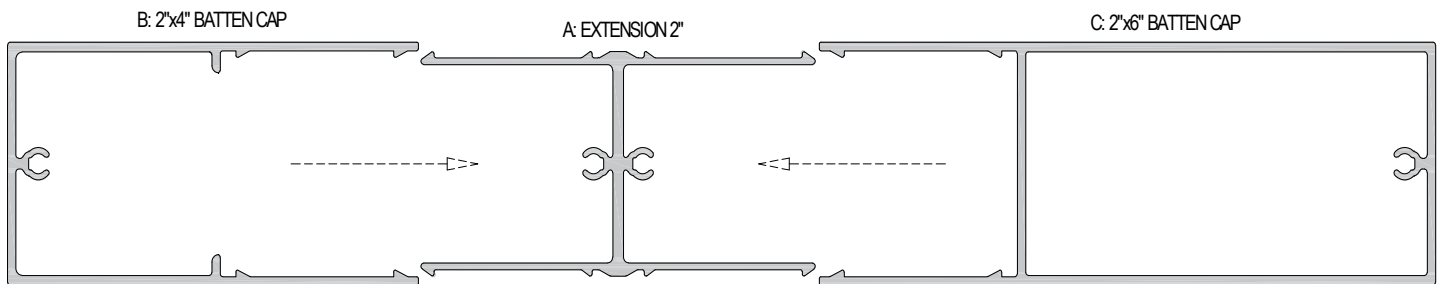

2" X 10" Batten Assembly

\*typical 0.070/0.080" wall thickness