



PRODUCT DATA SHEET AP400 ALUMINUM PLATE

Product Name

AP400 Aluminum Plate Rainscreen System

Manufacturer

Lumabuilt (RMP Architectural Solutions)
Lumabuilt.com

Product Description

AP400 Aluminum Plate is an exceptionally high-performance, architectural aluminum façade. AP400 Aluminum Plate was created with flexibility and ease of the designer in mind. Equally effective as an exterior rainscreen application or in the interior space, AP400 Aluminum Plate comes in several of solid aluminum gauges to meet your specification needs. Using the same licensed, proprietary, sublimation technology as Mosaic, AP400 Aluminum Plate can be finished in a variety of color and visual texture options including wood, marble, granite or just about any custom color you can imagine. AP400 Aluminum Plate offers a durable solution ideal for high traffic areas including lobbies, elevator wraps, or interior gathering spaces. As a 100% recyclable material made in the USA, AP400 Aluminum Plate can also help your project meet many of your green building initiatives.

Technical Data

- Class "A" Fire Rating.
- Paint finish testing: AAMA 2604
- NFPA 285 compliant
- Maximum Fabricated Panel: 46" (width) X 118" (length).
- System Depth: SEE TABLE
- Available in .080", .090", .100", .125" thick aluminum sheets.

Warranty

Wood grains 15 year standard warranty. Wood Grains 20 year specialty warranties on request. Solid Colors 10 year standard warranty Refer to warranty form for full details.

Installation

AP400 Aluminum Plate Panel installed mechanically with clips to allow for thermal movement of the system Refer to installation instructions for full details.

Maintenance

To preserve the original beauty of AP400 Aluminum Plate products a regular cleaning schedule is suggested. In general, panels may be cleaned using warm water and a mild detergent (if necessary). Refer to cleaning instructions for full details.





PRODUCT DATA SHEET AP400 ALUMINUM PLATE

Product Information:

- Architectural Rainscreen Panel for interior, or exterior applications.
- Available in .080", .090", .100", .125" thick aluminum sheets.
- Paint Finishes: Solid colors, woodgrains, and specialty finishes.
- System Depth: SEE TABLE
- Maximum Fabricated Panel: 46" (width) X 118" (length).
- Panel installed mechanically with clips.

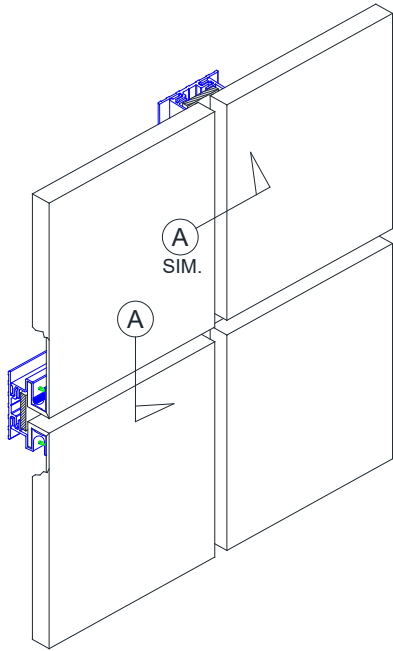

Technical Overview:

- Fire Rating & Testing: Class "A" Rating, ASTM E2768/E84, ASTM E136
- Paint Finish Testing: AAMA 2604

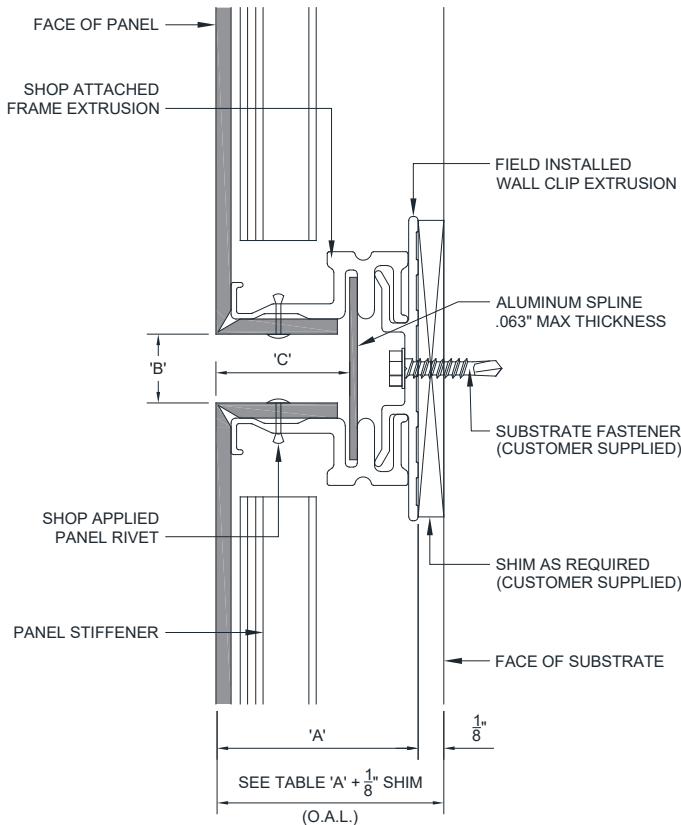

AP400 SERIES RAINSCREEN SYSTEM
(SECTION A - HORIZONTAL & VERTICAL PANEL JOINT)

Lumabuilt AP400 Dimensions			
ALUMINUM THICKNESS	'A'	'B'	'C'
.080"	1.638"	.655"	1.056"
.090"	1.648"	.635"	1.066"
.100"	1.658"	.615"	1.076"
.125"	1.683"	.565"	1.101"

