



Design Guidelines



Lumabuilt



The instructions in the Design Guidelines are strictly for illustration purposes and may not be applicable to all building designs or product installations. All projects should conform to applicable building codes for that area. It is recommended to follow all building regulations and standard industry practices. Lumabuilt reserves the right to modify, without notice, any details, recommendations, or suggestions contain heir in.

It is recommended that Mosaic is to be installed by a professional erector who is specifically experienced with the installation of aluminum soffits and siding materials and who utilizes the correct practices and techniques to safely and properly handle any equipment and materials required to complete the installation of this product.

Mosaic has a durable, yet unique wood grain/solid color powder coating applied to it which must be handled, cut, and installed in an appropriate manner as to not damage the finish.



DESIGN DETERMINATION

As you work through the design process it is important to plan the overall layout of the installation. Consult the architectural drawings to aid you in the intended finished look. At this time, you must define several items that will impact the finished look of your installation.

PLANK DIRECTION CONSIDERATIONS

- The direction of the planks is very comparable to the requirements for the plank supports. How will you make the required panel attachments?
- Will additional framing be required?
- Plank layout needs to be balanced from edge to edge. Define the desired look (what is the focal point)
- Penetrations and the impact of them should be taken into consideration; (doors, windows, lighting, fire sprinklers, access panels, signage etc.).

PANEL END JOINT LAYOUTS

- Minimizing the joints is the best practice (thermal movement happens)
- If area and size allow, no exposed panel end joints are best
- Panel end joint trims can be used to conceal joints and cut edges
- Panel end joints can be staggered to present an effect (Wood grains will be interrupted)
- Panel end joints can be aligned to present an effect (Wood grains will be interrupted)

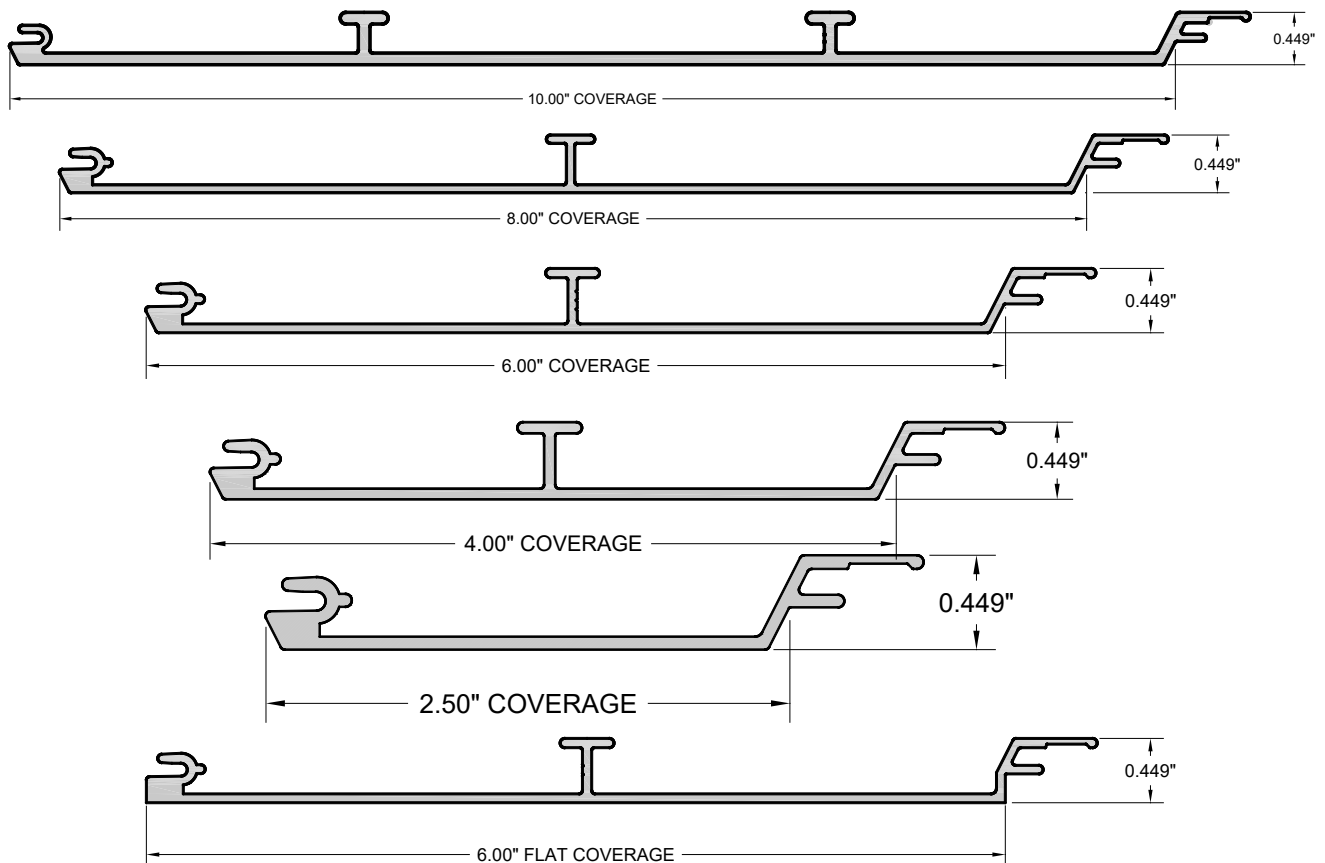



PLANKS & PLANK CLIP



2.5" V-GROOVE PLANK

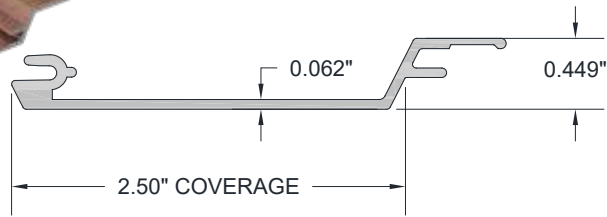

3/4" long stainless steel clips - allows for thermal expansion.



4" V-GROOVE PLANK

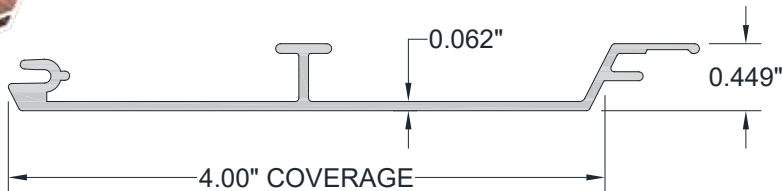

6" V-GROOVE PLANK

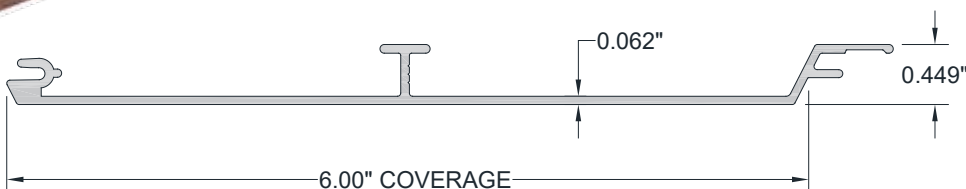

PLANKS & PLANK CLIP

8" V-GROOVE PLANK

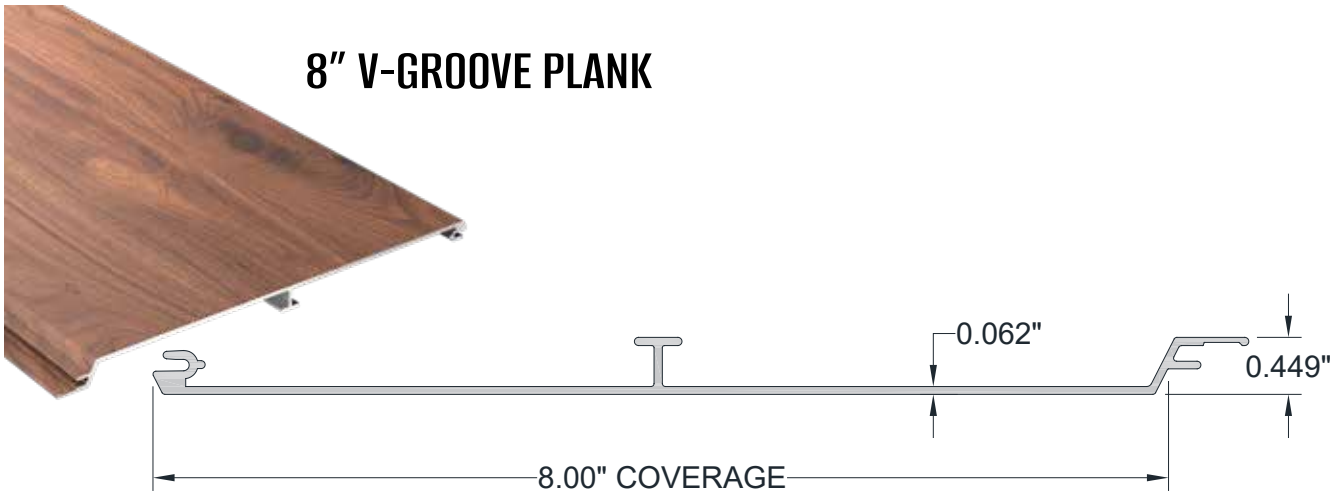

10" V-GROOVE PLANK

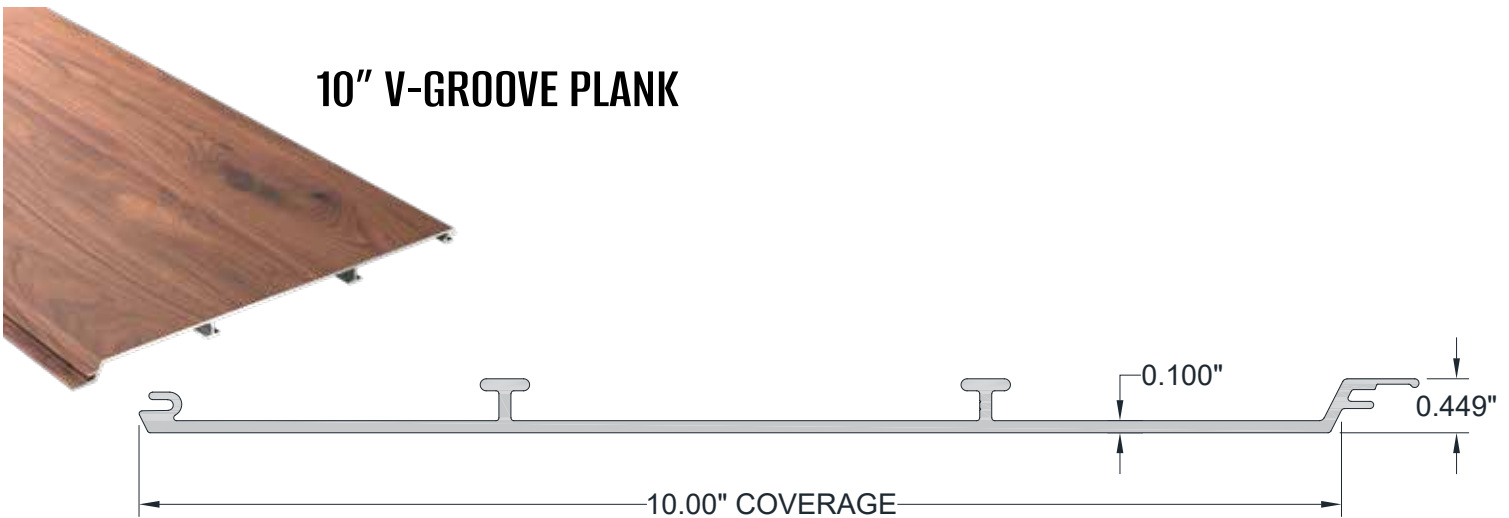

6" FLUSH PLANK

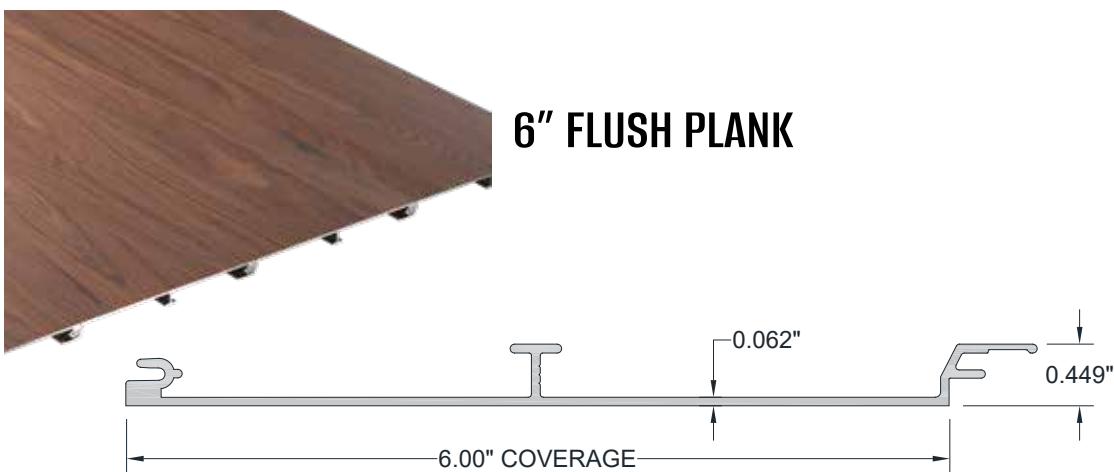



WOOD GRAIN VARIATIONS

Wood grain patterns offer a natural variation to simulate a wood product.

- Patterns will vary within the width and length of the part
- Patterns will repeat over a certain distance on a part

To ensure the best aesthetic desired look, you must layout the materials on a surface large enough to identify the finish variations prior to install. Make product adjustments to each area by moving the planks to other locations to achieve the desired look.

Trim wood grains will vary on the trims like the planks. You must ensure the trim wood grains provide you the desired look at time of layout. You can control this look by selecting another trim part or shifting its location within the layout.

SUB-FRAMING REQUIREMENTS - Mosaic planks can be installed over a solid surface provided it meets the flatness and attachment criteria. They can also be installed over open framing or furring (hat channels) to aid in achieving a flat surface.

DRY-IN - Mosaic is a rain-screen system. If your application requires a watertight result, you must prepare your substrate with the proper underlayment's to meet the desired results.

FACTORY PLANK ENDS - Mosaic is a nominal 24' long plank. Due to production limitations your installation may require a fresh cut at one end, or both ends of each plank to meet the aesthetic values of the install. Please ensure you plan for the fresh cut in your measuring prior to final cuts.

TOUCH UP CUT ENDS - As you perform the install element of each project you may find the need to darken the fresh cut ends of the planks and the trim elements. Lumabuilt offers two colored touch pens for this use (Dark and Light Brown). The application is best used to select the closest color to your project. If neither color is a match, then you may mix to a desired consistency to best fit your application.

CUSTOM TRIM PARTS - Lumabuilt offers a complete trim package for this system. However, at times the design may require a special size or shape of trim. We offer the ability to fabricate .050 aluminum custom trim shapes and apply the same finish to match the system.



UNDERSTANDING EXPANSION & CONTRACTION

The expansion coefficient for aluminum will cause thermal movement over the length of each plank: ($\frac{3}{16}$ " inch over 24' feet) per 100° Fahrenheit of temperature change. Panel attachment locations are critical to direct the panel movement to be concealed in a successful installation. Mosaic is installed utilizing a stainless-steel floating panel clip. This allows for panel movement during thermal changes.

The planks will both expand and contract by the same amount. Mosaic should be installed so that the end of the plank is at the midpoint in the trim components. This will allow for the plank to both expand and contract without being constrained by the trim pieces.

Do not fasten Mosaic planks to the trim components as this will inhibit thermal movement.

TYPICAL SINGLE 24' LONG PLANK ATTACHMENT:

Plank clips and fasteners are to be installed at 16" on center (review load span tables to confirm spacing). A fixed point is required for each plank, best located at the midpoint of the plank. One fastener should be installed at the plank's midpoint directly through the clip attachment surface to provide a fixed attachment and prevent plank migration to the left or right.

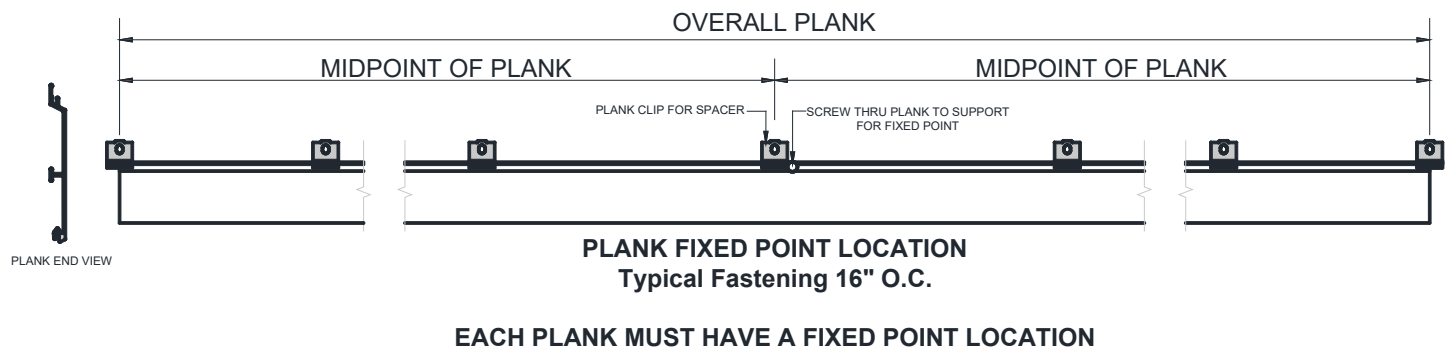



PLANK LAYOUT OPTIONS

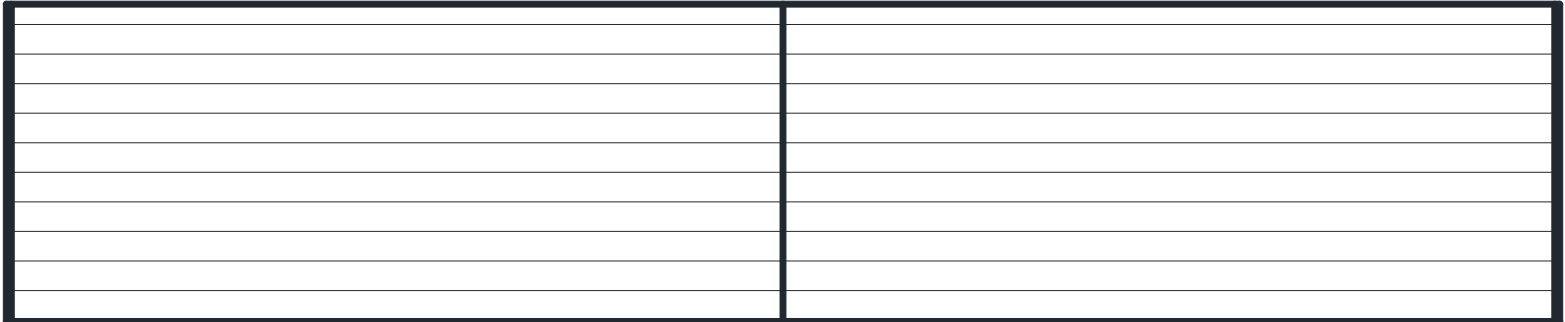

**LAYOUT 24' LONG PLANKS
JOINTS ALIGNED AT 24'**

(6" PLANKS SHOWN IN A 40' LONG RUN)

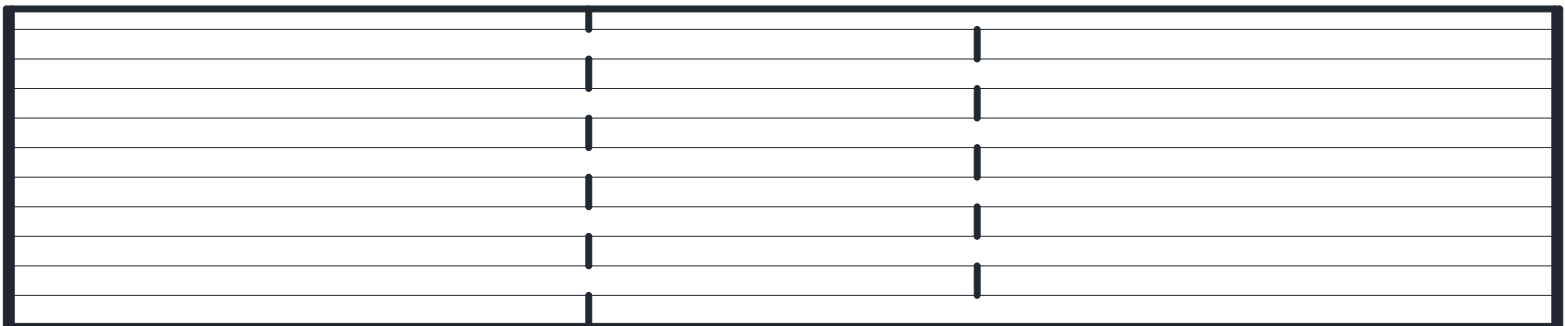

**STAGGERED JOINT LAYOUT 24' LONG PLANKS
STAGGERED JOINT**

(6" PLANKS SHOWN IN A 40' LONG RUN)

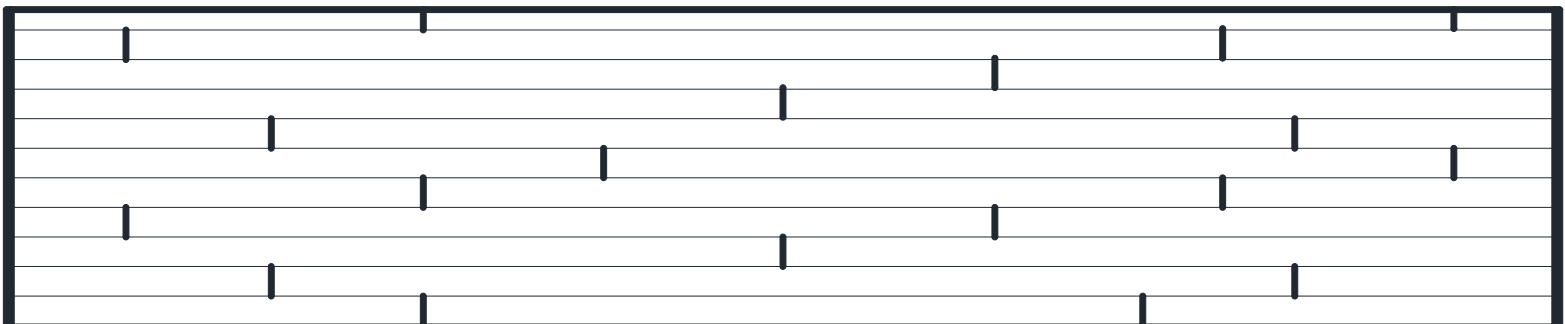

**RUNNING BOND LAYOUT 24' LONG PLANKS
STAGGERED JOINT 4'**

(6" PLANKS SHOWN IN A 40' LONG RUN)



TRIM PROFILES

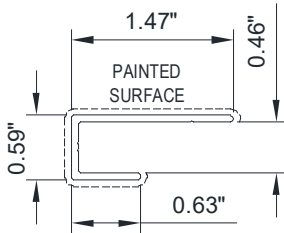

J CLOSURE

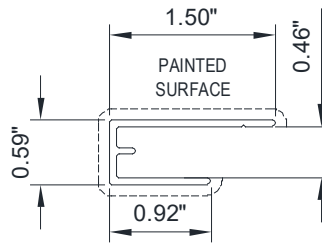

J STARTER

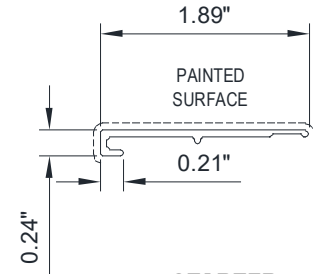

STARTER

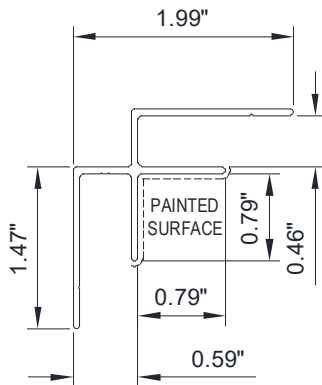

INSIDE CORNER

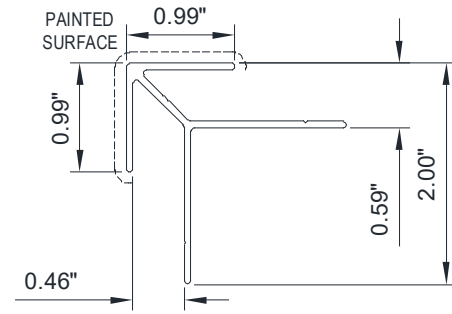

OUTSIDE CORNER

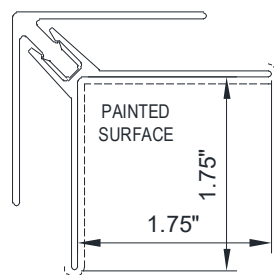

2 PC INSIDE CORNER

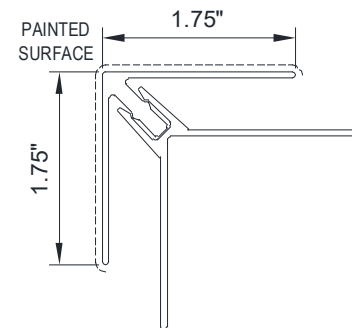

2 PC OUTSIDE CORNER



TRIM PROFILES

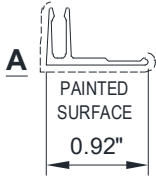

EDGE BASE

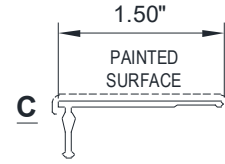

EDGE TOP

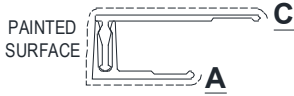

EDGE BASE & TOP ASSEMBLY

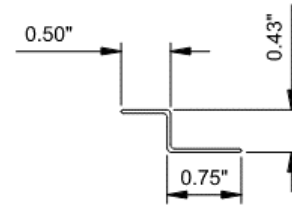

ZEE SUPPORT

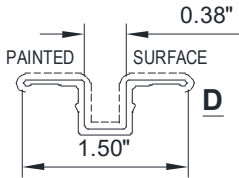

JOINT TOP REVEAL

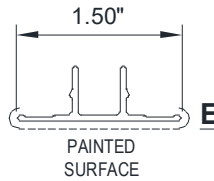

JOINT TOP

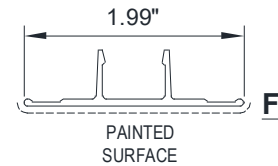

JOINT BASE

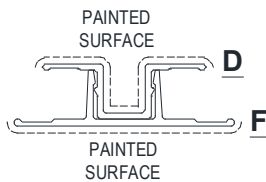

JOINT BASE & TOP REVEAL ASSEMBLY

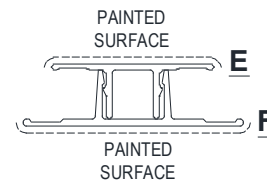

JOINT BASE & TOP ASSEMBLY



TRIM APPLICATION

Prior to panel installation it is required to understand the best applications for the trims. Trim components are sold in 12' lengths only, they are intended to be field cut to fit each specific application. Using a square cut or miter cut you can complete the layout appearance you desire. You can use the trim to cover the ends of each plank. Additionally, you can use the trim to create a element of design. The main purpose for the trim components is to provide for the thermal expansion and cover the necessary field cuts to the planks.



STARTER - Used at the starting point of installation, generally this is a bare finish extruded aluminum part designed to hold the non-clip leg of the panel in place. This part will need to be installed prior to planks. This is to be used in a continuous manner.



J- CLOSURE - Is a universal part designed to have the plank slid into its shape. This can be used parallel or perpendicular to the plank. This part is finished to match the planks.



J-STARTER -Is a universal part designed to have the plank slid into its shape specifically used to replace the need for a stand alone starter and J-closure combination. This can be used parallel or perpendicular to the plank. This part is finished to match the planks.



TRIM PROFILES



EDGE ASSEMBLY TERMINATION - This is two-part trim element to be used at the edge or perimeter of the planks. The base trim will need to be installed prior to the plank installation. When the planks are completely installed you then can insert in the top part of the assembly. Both parts are finished to match the planks.

Special Instructions: this assembly can be reversed in the installation to accommodate an alternate face dimension width.



JOINT ASSEMBLY - This is two-part trim element to be used when you need to bring two ends of planks together. This can be at any angle (Directional Transitions, Miters etc.). The base trim will need to be installed prior to the plank installation. When the planks are completely installed you then can insert in the top part of the assembly. Both parts are finished to match the planks.

Special Instructions: this assembly can be reversed in the installation to accommodate an alternate face dimension width.



JOINT ASSEMBLY REVEAL - This is two-part trim element to be used when you need to bring two ends of planks together. This can be at any angle (directional transitions, miters etc.). The base trim will need to be installed prior to the plank installation. When the planks are completely installed you then can insert in the top part of the assembly. Both parts are finished to match the planks.



OUTSIDE CORNER - This trim is to be used at any application you need to turn a 90-degree corner. This part will need to be installed prior to the planks. This part is finished to match the planks.

TRIM PROFILES



INSIDE CORNER - This trim is to be used at any application you need to turn a 90-degree corner. This part will need to be installed prior to the planks. This part is finished to match the planks.



2 PIECE INSIDE /OUTSIDE CORNER ASSEMBLY - This trim is to be used at any application you need to turn a 90-degree corner. This part will need to be installed prior to the planks. This part is finished to match the planks.



ZEE SUPPORT - This concealed trim element is used with a rip cut plank at a termination condition. This part will be installed prior to the planks at the termination trim piece. A piece of VHB tape (3M 4905 or Equivalent - purchased separately) will secure the termination plank to the zee support piece.





Lumabuilt offers a complete set of details to clarify and define the many options for each trim combination for your application. All the latest details are available on the website Lumabuilt.com.

WALL AND SOFFIT APPLICATION DETAILS

- Installation over open framing or solid surface
- Panel joint applications
- Termination conditions
- Penetrations
- Venting options
- Access panel

CALCULATING MATERIAL USAGE - Material take offs and quoted quantities were originally based on the layout from either the architectural drawings or the physical project requirements, you may see the need for changes as you define your plank layout and trim. *You should always include the necessary extra material to your order to accommodate any unforeseen circumstances. Installing the material in a pattern other than what has been predetermined at time of order may result in material shortages.*

NOTE: materials are sold in standard sizes

Planks 4" 6", 8" and 10" wide are available in 12'-0" or 24'-0" long. Based on each area of plank and the desired layout ensure you plan to utilize your material drop.

All trims are 12'-0" long

All .050 custom flashings are 10'-0" long

For best results the trim should utilize full length pieces as often as you can. It is not recommended to use a series of short trim pieces to complete an area that would be best served with a full-length part.





Lumabuilt

Design Guidelines

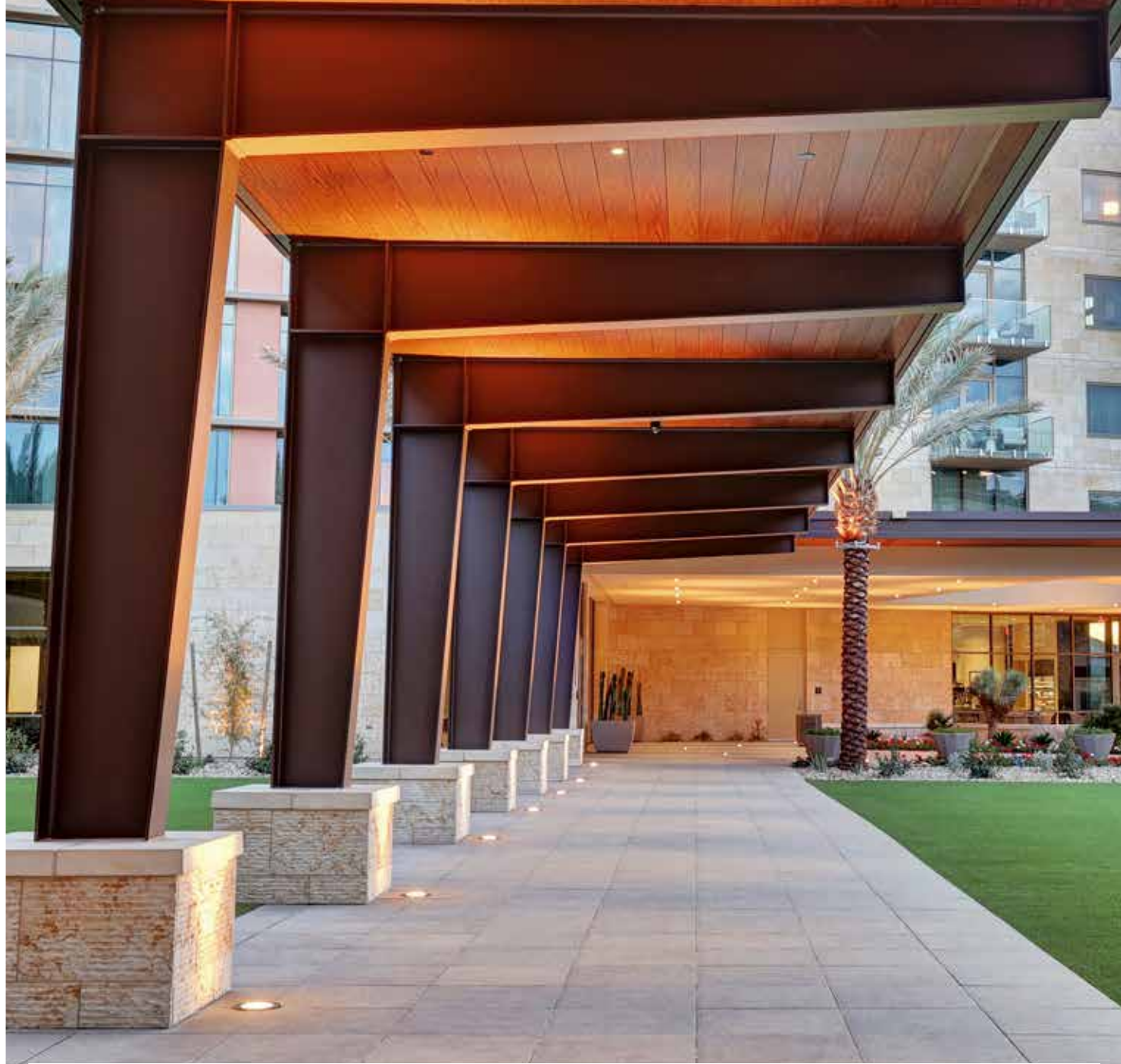

Lumabuilt

2529 W. Jackson St. | Phoenix, AZ 85009
602.275.1676 | Info@Lumabuilt.com
For more info visit: Lumabuilt.com

LB23-062 ©2023 Lumabuilt. All Rights Reserved. Revised 05.03.2024

