



SOLID BATTENS

Mosaic Solid Battens are extruded aluminum profiles available in multiple sizes to accommodate a range of design and structural requirements. The solid, one-piece profile creates a continuous, uninterrupted visual line across the installation. Battens are typically installed using exposed bracket systems, providing a straightforward attachment method that allows for consistent alignment, reliable support, and efficient installation in the field.

Product Information

- The perfect architectural solution for a variety of exterior and interior applications including sunshades, privacy screens, fencing, and decorative elements.
- Made of 6063-T6 extruded aluminum alloy.
- Both prepunched and t-shaped end caps available.
- Lightweight, durable and our licensed proprietary sublimation process makes its beauty last for years.

Available Finishes

Solid colors, woodgrains, and specialty finishes.

Visit lumabuilt.com to view all available finishes.

Warranty

Woodgrains: 15-year standard warranty (20 year specialty warranties on request)

Solid Colors: 20-year standard warranty

Full details are available at lumabuilt.com.

Testing Information

- System Testing with CA & PA Stamps: ASTM E2768/E84, ASTM E136, AAMA 1402
- Paint Finish Testing: AAMA 2605
- Fully ICC Certified: ESR-5449
- Class "A" Fire Rating
- FL Supplement with HVHZ (ESR-5449)

SOLID BATTENS

PROFILE/PRODUCT	LENGTH	WEIGHT
1" x 3" Solid Batten	24"	.716 lb/ft
1" x 4" Solid Batten	24"	.869 lb/ft
1" x 5" Solid Batten	24"	1.025 lb/ft
1" x 6" Solid Batten	24"	1.180 lb/ft
1" x 8" Solid Batten	24"	1.947 lb/ft
2" x 8" Solid Batten	24"	2.183 lb/ft
2" x 8" 6-Screw Boss Solid Batten	24"	2.934 lb/ft
4" x 10.75" Cee Fin	24"	4.898 lb/ft

* Custom lengths are available upon request. Order minimums may apply.

EXPOSED BRACKETS

PROFILE/PRODUCT	LENGTH	WEIGHT	THICKNESS
1" U Bracket	3" - 12"	.111 lb/ft	.125"
2" U Bracket	3" - 12"	.221 lb/ft	.125"
L Bracket	3" - 12"	.110 lb/ft	.125"
Angle Bracket	3" - 12"	.115 lb/ft	.125"



SOLID BATTENS

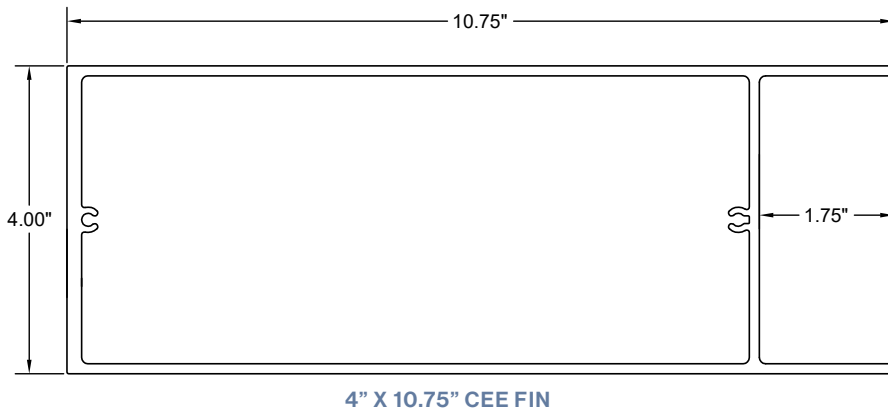
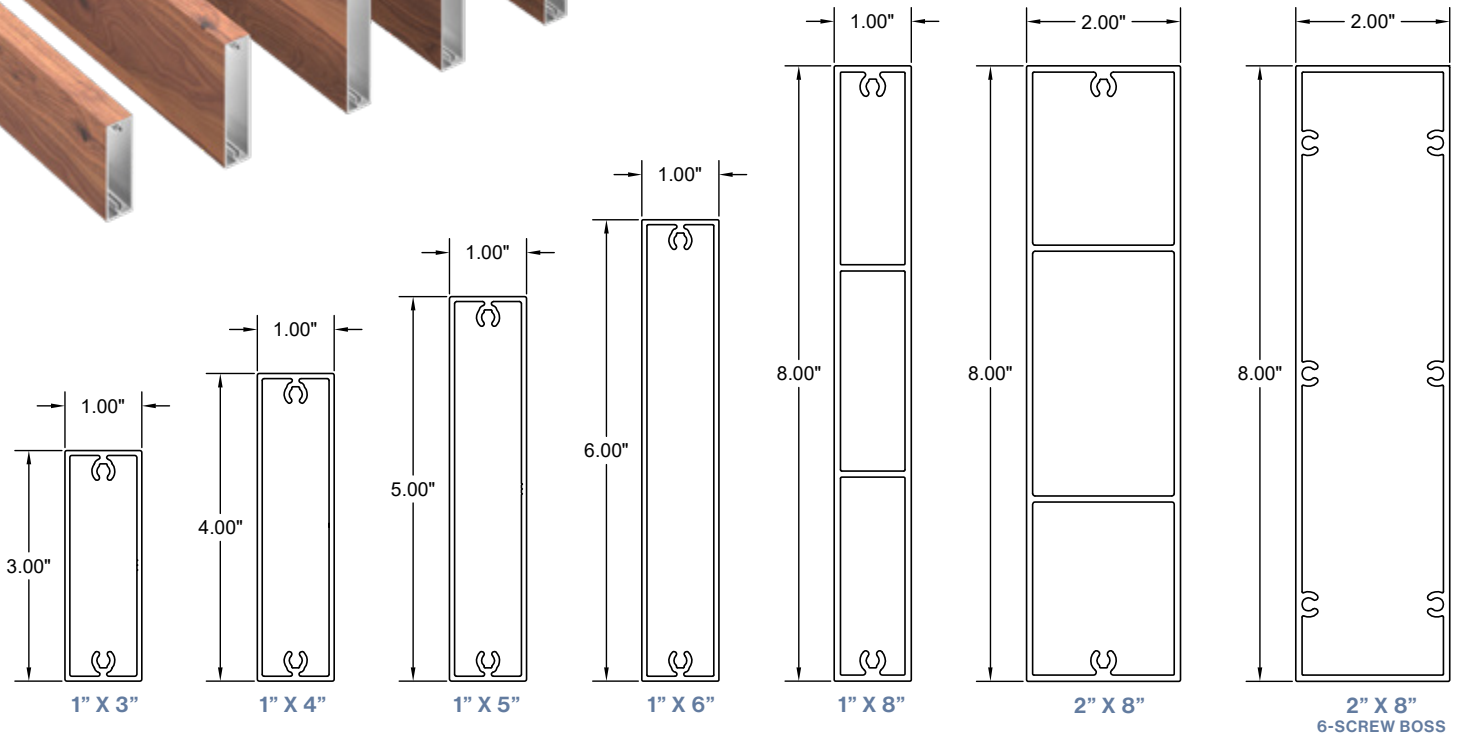

EXPOSED BRACKETS

Exposed brackets are powder-coated aluminum components designed to remain visible as part of the finished installation. Brackets are fastened directly to the substrate, with battens secured to the brackets during installation. Slotted holes in the bracket allow for thermal expansion and adjustment while maintaining consistent alignment.



1" U BRACKET

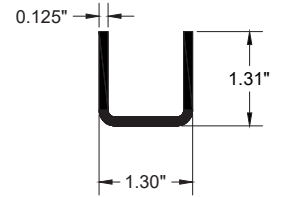

Available in the following lengths:
3", 4", 5", 6", 8"

2" U BRACKET

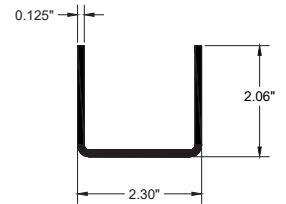

Available in the following lengths:
3", 4", 5", 6", 8", 10", 12", 14", 16"



L BRACKET

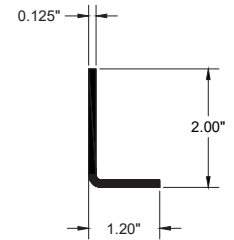

Available in the following lengths:
3", 4", 5", 6", 7", 8", 10", 12", 14", 16"

ANGLE BRACKET

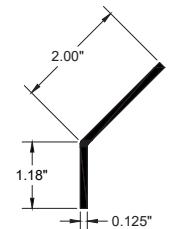

Available in the following lengths:
3", 4", 5", 6", 8", 10", 12", 14", 16"

END CAPS

Mosaic Batten End Caps are designed to provide a finished termination for all Mosaic batten profiles, creating the appearance of a continuous, solid beam. Each end cap is manufactured and finished to match the corresponding batten in color and woodgrain pattern for visual consistency. End caps are available for all Mosaic batten types and sizes, allowing for a complete, integrated system across a wide range of applications.

